



Level



Pressure



Flow



Temperature



Liquid
Analysis



Registration



Systems
Components



Services



Solutions

Technical Information

Viomax CAS51D

Photometric sensor for SAC or nitrate measurement



Application

- Monitoring and controlling of water treatment plants
- Monitoring of surface waters

Nitrate measurement

- Nitrate measurement in natural waters
- Monitoring of nitrate content in the outlet of wastewater treatment plants
- Monitoring of nitrate content in activated sludge basins
- Monitoring and optimizing denitrification processes

SAC measurement

- Organic load in the inlet of wastewater treatment plants
- Organic load in the outlet of wastewater treatment plants
- Inlet monitoring
- Organic load in drinking water

Your benefits

- Economy-priced and ecological measuring process:
 - No sampling or conditioning system required
 - No chemicals required
 - Service friendly design
- Measured value preparation in the sensor:
 - Low interference susceptibility on signal transfer
 - Very short response time
- Recognition of load peaks:
 - In time
 - Instantaneous
 - Without gap
- Thanks to factory calibration "ready to use"
- Standardized communication (Memosens technology) allows "plug and play"
- Cleaning system with pressurized air allows very long maintenance cycles.
- Calibrations provided by the customer with up to 5 points – realizable in lab or on site.
- Sensor version for nitrate or SAC available
- Nitrate: Representation as NO_3 or $\text{NO}_3\text{-N}$
- SAC: Representation as specific absorption coefficient (1/m), as $\text{COD}_{254\text{nm}}$ $\text{BOD}_{254\text{nm}}$ or $\text{TOC}_{254\text{nm}}$

Function and system design

Measuring principle

The light from a pulsed, high-stability strobe lamp (item 5) passes through the measurement section (items 3 and 4).

The beam splitter (item 2) directs the light beam to the two receivers (items 1 and 6). A filter is arranged upstream of each receiver. The filter upstream of the measuring receiver (item 1) only lets through light in the measuring wavelength range, while the filter upstream of the reference receiver (item 6) only lets through light in the reference wavelength range.

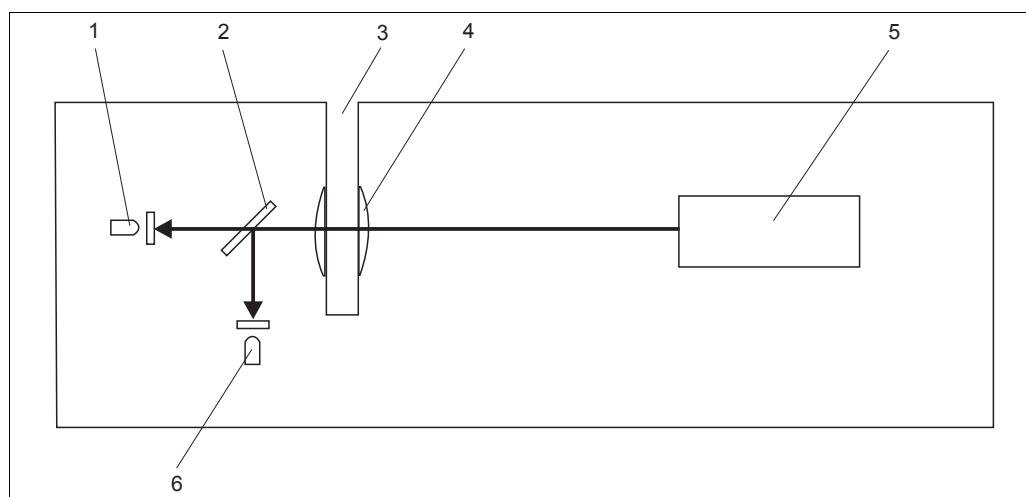

Principal mode of operation of the nitrate sensor

- 1 Measuring receiver with filter
- 2 Beam splitter
- 3 Cuvette
- 4 Lens
- 5 Strobe lamp
- 6 Reference receiver with filter

Nitrate measurement

Nitrate ions absorb UV light in the range from approx. 190 to 230 nm. Nitrite ions have a similar absorption rate in the same range.

In the cuvette, the nitrate and nitrite ions absorb the UV light in the measuring wavelength range in proportion to the nitrate and nitrite concentration, while the UV light in the reference channel at 254 nm remains virtually unchanged.

Interference factors such as turbidity, fouling or organic hydrocarbons are eliminated by mathematical means. The signal ratio between the reference channel and the measuring channel is used as the measurement result. This ratio is converted to the concentration of nitrate using the calibration curve programmed into the sensor.

Interferences at nitrate measurement

The measuring range is affected by the:

- dry substance
- age of the sludge
- color
- chemical oxygen demand (COD)
- temperature.

Trends:

- Higher dry substance content reduces the maximum measured value, i.e. narrows the measuring range.
- Equal dry substance content, but different color, leads to different measuring ranges/measured values.
- COD > 100 mg/l affects the measured value at nitrate concentrations below 1 mg/l.

SAC measurement

Many organic substances absorb electromagnetic radiation in the range of 254 nm. The SAC sensor uses the absorption of the measuring wave length (254 nm) and the undisturbed reference measurement at 550 nm. For SAC measurement KHP (potassium hydrogen phthalate $C_8H_5KO_4$) is used for organic reference. The sensor is factory calibrated with KHP.

The conversion to COD_{254nm} and TOC_{254nm} is performed in the following way:

$$c (TOC) = 0.4705 * c (KHP)$$

$$c (COD) = 1.176 * c (KHP)$$

The relation to SAC (based on KHP) is calculated in the following way:

$$1 (1/m) = 1.487 \text{ mg/l } COD_{254nm} = 0.595 \text{ mg/l } TOC_{254nm}$$

Many substances have a different absorption characteristic compared to KHP. Therefore a calibration on customer site is recommended.

Interferences at SAC measurement

The measuring range is affected by the:

- COD
- Color

Trends:

- COD absorbing at 550nm impacts the measuring result. In this case a comparison or a calibration is necessary.
 - Colorations absorbing in the green spectral range reduce the measuring value.
 - COD with spectral characteristics at measurement or reference wavelength different to KHP (potassium hydrogen phthalate) impacts the measuring result. In this case a comparison or a calibration is necessary.
-

Sensor monitoring

The optical signals are continuously monitored und checked for plausibility
Discrepancies are reported via error messages by the transmitter.

The sensor check system of the Liquiline M reports the following failure conditions:

- Implausible high or low measuring values
- Disturbed controlling due to erroneous measuring values

Measuring system

A complete measuring system comprises:

- Nitrate sensor Viomax CAS51D
- Transmitter Liquiline
- Assembly Flexdip CYA112 and holder system Flexdip CYH112 or
- Flow assembly (Flowfit CYA251 or 71110000)

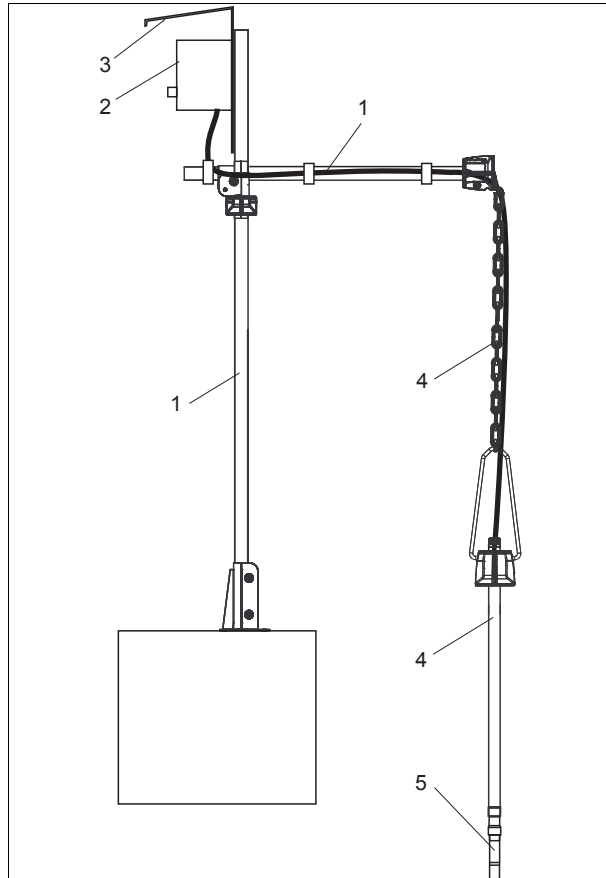

- 1 Holder system Flexdip CYH112
- 2 Transmitter Liquiline
- 3 Weather protection roof
- 4 Assembly Flexdip CYA112
- 5 Nitrate sensor Viomax CAS51D

Measuring system with immersion assembly (example)

a001.3351

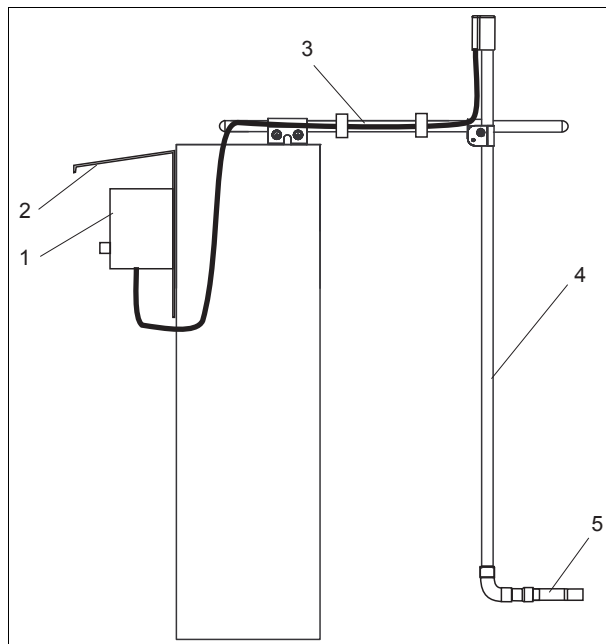

- 1 Transmitter Liquiline
- 2 Weather protection roof
- 3 Holder system Flexdip CYH112
- 4 Assembly Flexdip CYA112
- 5 Nitrate sensor CAS51D

Measuring system with immersion assembly (example)

a001.3333

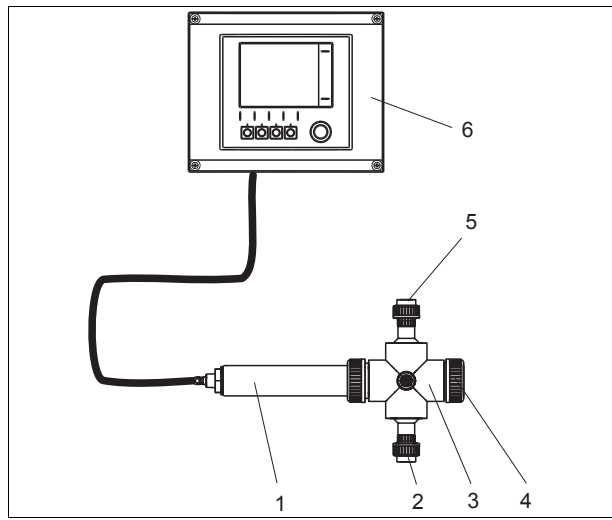

- 1 Sensor Viomax CAS51D
- 2 Inlet
- 3 Flow assembly Flowfit CYA251
- 4 Sealing cap
- 5 Outlet
- 6 Transmitter Liquiline

Measuring system with flow assembly (example)

Input

| | | | |
|--------------------------------------|---|--|--|
| Measuring variables (nitrate) | NO ₃ -N (mg/l), NO ₃ (mg/l) | | |
| Measuring variables (SAC) | SAC _{254 nm} (1/m), COD _{254 nm} (mg/l), TOC _{254 nm} (mg/l), transmission (%) | | |
| Measuring range | CAS51D-**A2 (2 mm gap) | 0.1 to 50 mg/l NO ₃ -N or 0.4 to 200 mg/l NO ₃ | Clear water + activated sludge |
| | CAS51D-**A1 (8 mm gap) | 0.01 to 20 mg/l NO ₃ -N or 0.04 to 80 mg/l NO ₃ | Clear water (for a content of COD (KHP) up to 125 mg/l and 50 FNU turbidity based on mineralic kaolin) |
| | CAS51D-**C1 (40 mm gap) | SAC 0.1 to 50 1/m COD 0.15 to 75 mg/l equiv. KHP TOC 0.06 to 30 mg/l equiv KHP | Clear water, mean measuring range, drinking water |
| | CAS51D-**C2 (8 mm gap) | SAC 0.5 to 250 1/m COD 0.75 to 370 mg/l equiv. KHP TOC 0.3 to 150 mg/l equiv KHP | Clear water, mean measuring range, outlet of wastewater treatment plants, monitoring of natural waters |
| | CAS51D-**C3 (2 mm gap) | SAC 1.5 to 700 1/m COD 2.5 to 1000 mg/l equiv. KHP TOC 0.9 to 410 mg/l equiv KHP | Organic load at inlet, inlet monitoring, industrial processes |

Power supply

The sensor will be connected to the transmitter as follows:

- With the M12 plug (version: fixed cable, M12 plug) or
- With the fixed cable connected to the terminal strips (version: fixed cable, end sleeves):

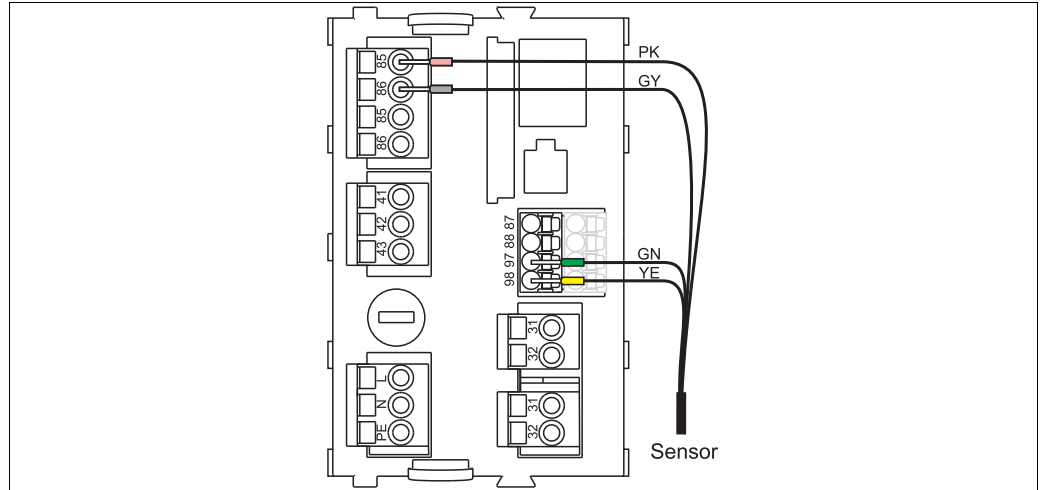

Sensor connection

20012460

The maximum cable length is 100 m (328 ft).

Performance characteristics

| | |
|---|--|
| Maximum measured error (nitrate) | For 0.1 to 50 mg/1 NO ₃ -N (2 mm cuvette gap): ±0.2 mg/1 below 10 mg/1 2 % of full scale value above 10 mg/1 For 0.01 to 20 mg/1 NO ₃ -N (8 mm cuvette gap): ±0.04 mg/1 below 2 mg/1 2 % of full scale value above 2 mg/1 |
| Maximum measured error (SAC) | 2 % of upper end of measuring range for measurement with potassium hydrogen phthalate (KHP) as standard |
| Limit of detection (SAC) | CAS51D-AAC1 0.045 mg/1 COD CAS51D-AAC2 0.3 mg/1 COD CAS51D-AAC3 1.5 mg/1 COD according to standard potassium hydrogen phthalate (KHP) |
| Limit of quantitation (SAC) | CAS51D-AAC1 0.15 mg/1 COD CAS51D-AAC2 1.0 mg/1 COD CAS51D-AAC3 5.0 mg/1 COD according to potassium hydrogen phthalate (KHP) |
| Repeatability (nitrate) | Min. ±0.2 mg/1 NO ₃ -N |
| Repeatability (SAC) | 0.5 % of end of measuring range (for homogeneous medium) |
| Drift (nitrate) | Less 0.1 mg/1 NO ₃ -N per week |
| Drift (SAC) | Less 0.2 % of end of measuring range per week |
| Cross sensitivity | 1.0 mg/1 nitrite will be displayed as 0.8 mg/1 nitrate. |

Installation conditions

Installation instructions

Mounting applications:

- with wastewater assembly Flexdip CYA112 and holder system Flexdip CYH112
- with flow assembly 71110000
- with flow assembly Flowfit CYA251

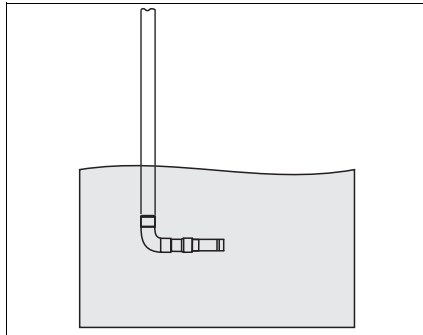

Installation with wastewater assembly

a0013267

The installation angle is 90°.

Align the sensor in the way the cuvette gap is cleaned by the flow.

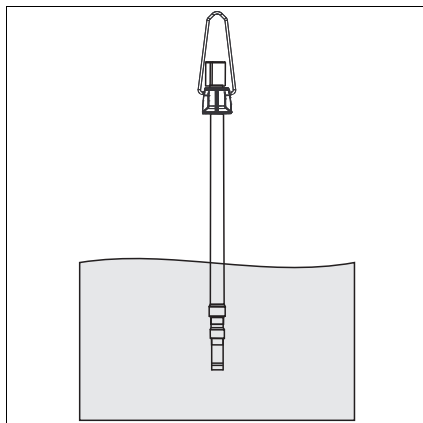

Installation with a chain holder system

a0013270

The installation angle is 0°.

The sensor can be installed at a chain holder system. Make sure that the cuvette gap is kept clean and no debris can build up on the optical windows.

Proven configuration for operation in aeration zones.

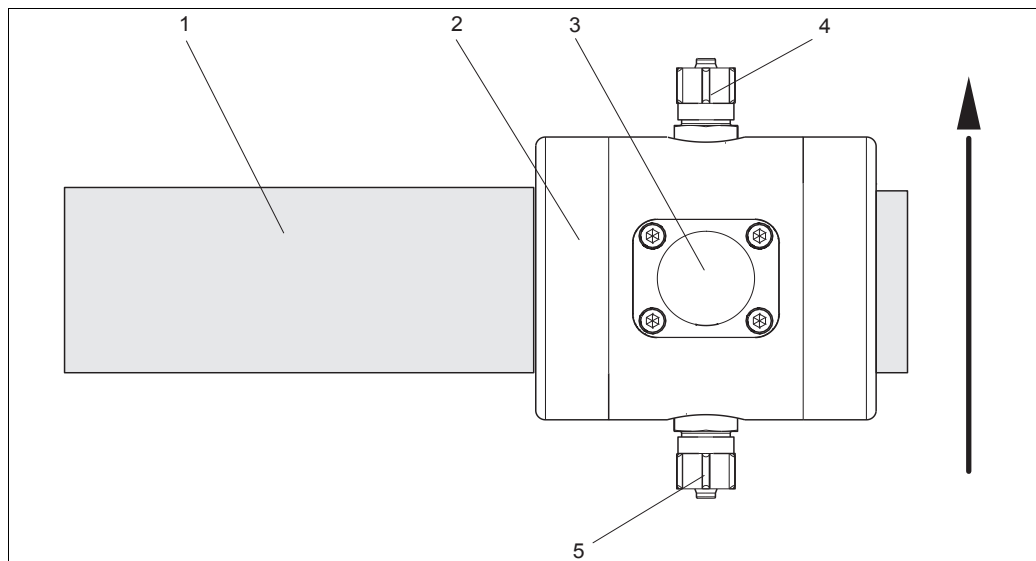

Sensor installed in flow assembly 71110000

a0013266

- 1 Sensor CAS51D
 - 2 Flow assembly
 - 3 Window, for sensor alignment
 - 4 Medium outlet
 - 5 Medium inlet
- Arrow shows flow direction

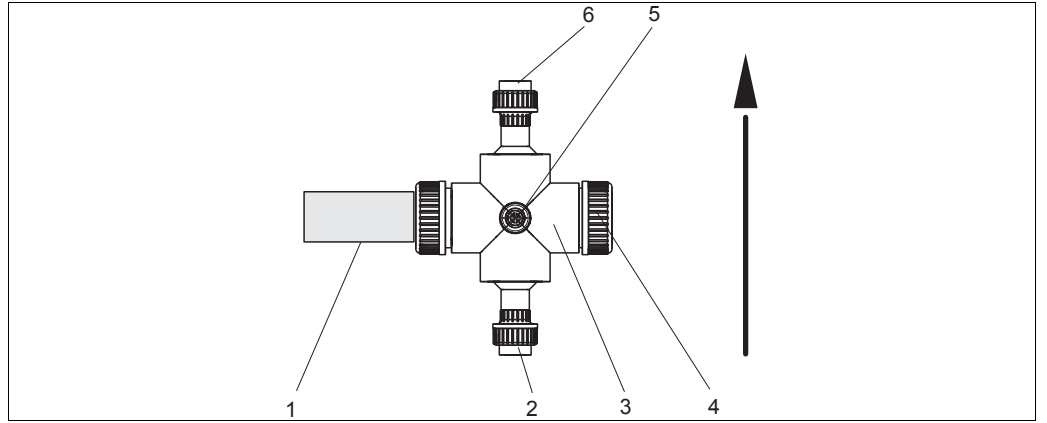

Sensor installed in flow assembly Flowfit CYA251

- 1 Sensor CAS51D
 - 2 Medium inlet
 - 3 Flow assembly Flowfit CYA251
 - 4 Sealing cap
 - 5 Rinse connection
 - 6 Medium outlet
- Arrow shows flow direction.

a0015004

Sensor alignment

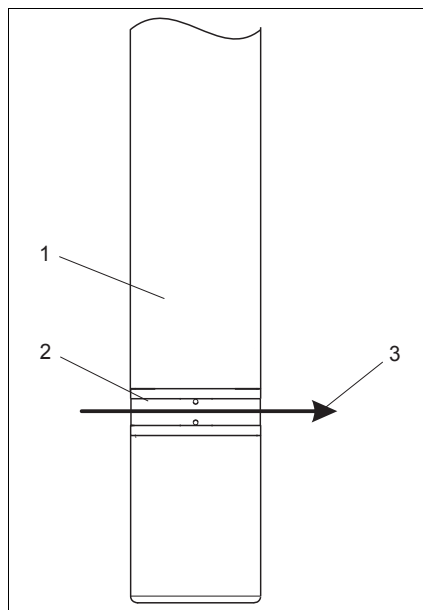

- 1 Sensor
- 2 Cuvette gap
- 3 Flow direction

Align the sensor in the way that the cuvette gap is cleaned by the flow.

Alignment of the sensor

a0013268

Environment

| | |
|----------------------------|---|
| Ambient temperature | -20 to 60 °C (-4 to 140 °F) |
| Storage temperature | -20 to 70 °C (-4 to 158 °F) |
| Ingress protection | IP 68 (1 m (3.3 ft) water column during 60 days, 1 mol/l KCl) |

Process

| | |
|----------------------------|---|
| Process temperature | +5 to 50 °C (41 to 120 °F) |
| Process pressure | 0.5 to 10 bar (7 to 145 psi) absolute |
| Minimum flow | No minimum flow required. Make sure that there is a sufficient turbulence for solids with a tendency to sedimentation. |

Mechanical construction

Dimensions

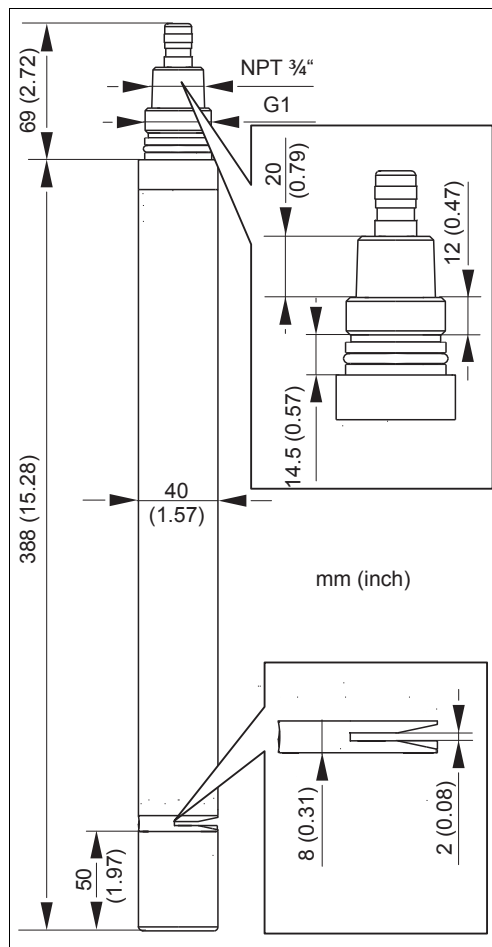

Dimensions CAS51D (2 mm gap)

a0013193

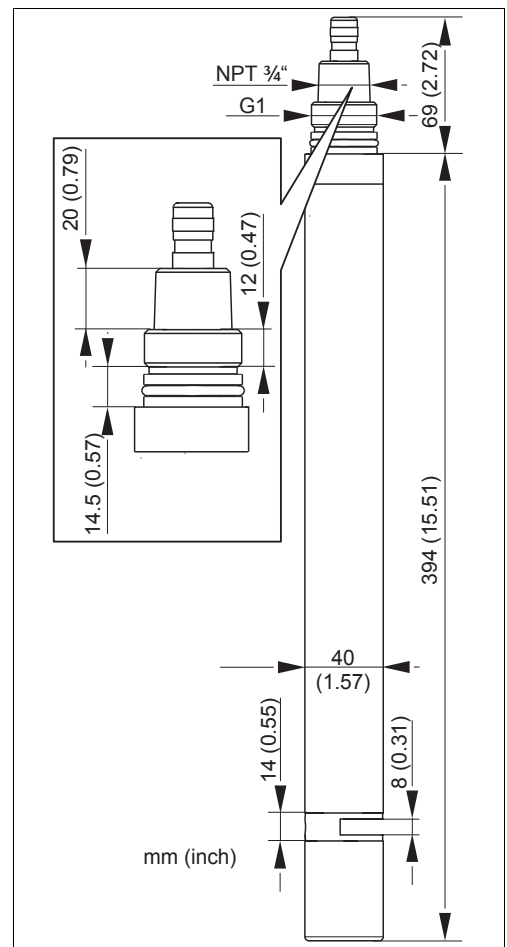

Dimensions CAS51D (8 mm gap)

a0013208

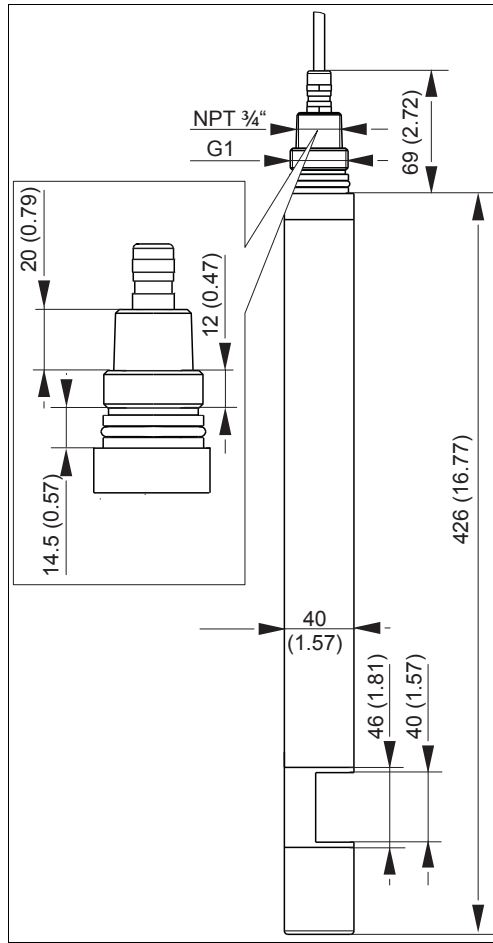

Dimensions CAS51D (40 mm gap)

a0014952

Weight approx. 1.6 kg (3.5 lbs) without cable

Materials
 Sensor stainless steel 1.4404 (AISI 316 L)
 Optical window Quartz glass
 O-rings EPDM

Process connections G1 and NPT 3/4"

Cleaning system

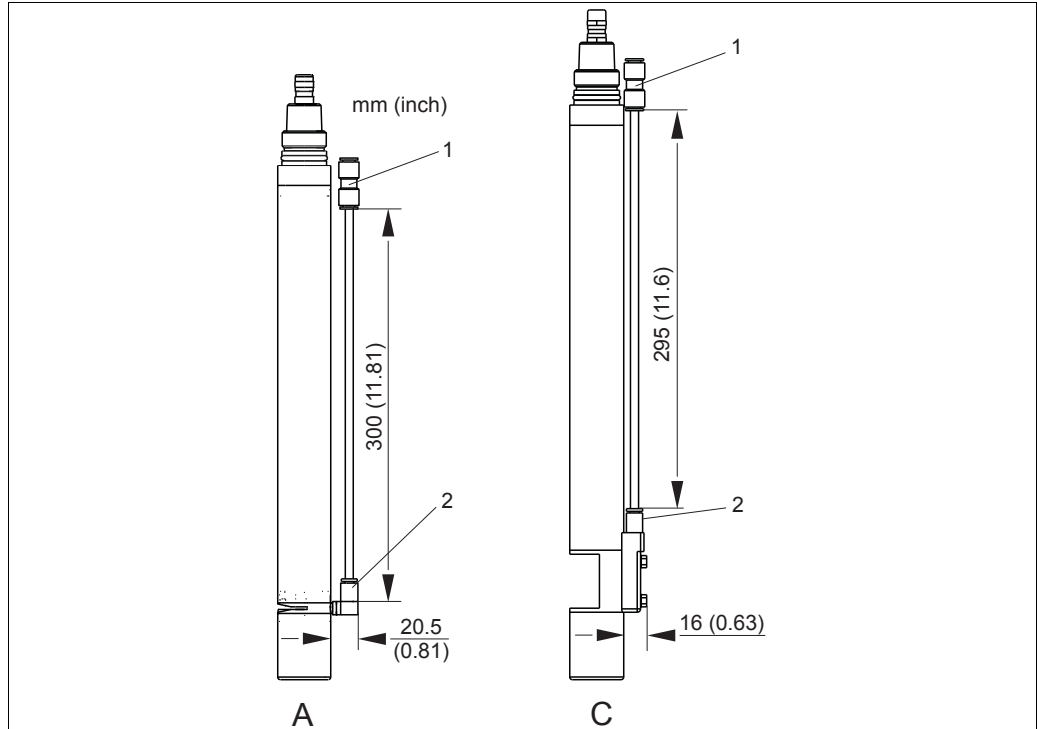

a0013292

CAS51D with cleaning system

- 1 Adapter 8 mm with 300 mm hose (only with connection 8 mm)
- 2 Connection 6 mm or 6.35 mm (1/4")
- A Sensor (2 mm or 8 mm gap)
- C SAC sensor (40 mm gap)

Flow assembly

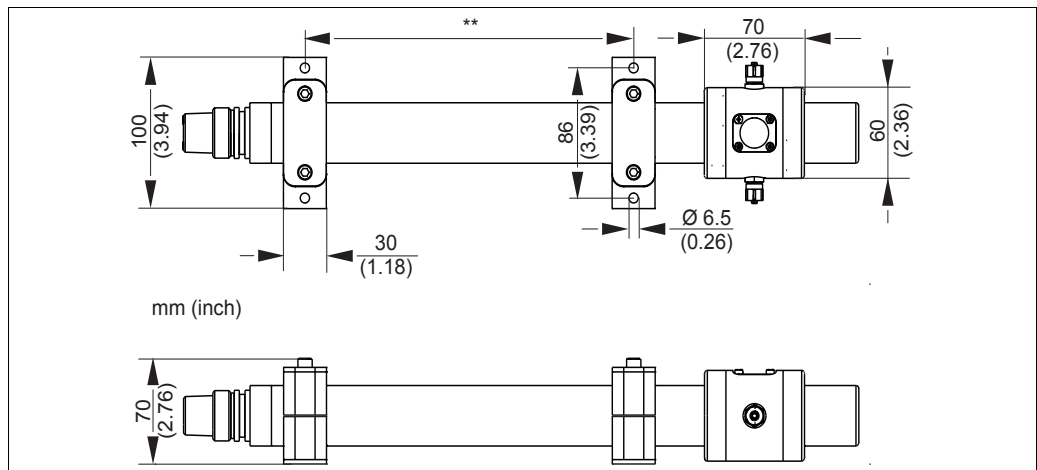

a0013290

CAS51D with flow assembly 71110000 and holder

** variable

Certificates and approvals

EMC compatability

Interference emission and interference immunity complies with EN 61326: 2005, Namur NE 21:2007

Ordering information

Product structure

| | | Approval | |
|---------|----|---|------------|
| | AA | Non-harzadous area | |
| | | Application, measuring range | |
| | A1 | Clear water 0.01 to 20 mg/1 NO ₃ -N or 0.04 to 80 mg/1 NO ₃ | |
| | A2 | Clear water + activated sludge 0.1 to 50 mg/1 NO ₃ -N or 0.4 to 200 mg/1 NO ₃ | |
| | C1 | SAC, 0.1 to 50 m 1/m | |
| | C2 | SAC, 0.5 to 250 m 1/m | |
| | C3 | SAC, 1.5 to 700 m 1/m | |
| | | Adaption cable | |
| | A | Fixed cable, crimp sleeves | |
| | B | Fixed cable, M12-plug | |
| | | Cable length | |
| | 2 | 3 m (9.9 ft) | |
| | 3 | 7 m (23 ft) | |
| | 4 | 15 m (49.2 ft) | |
| CAS51D- | | | order code |

| Accessories mounted | |
|---------------------|------------------------------|
| IA | Air cleaning, 6/8 mm |
| IB | Air cleaning, 6.35 mm (1/4") |

Note!

To complete your order code, simply add the accessories code to the end of order code. If you have any questions, please contact your local sales office.

Scope of delivery

The scope of delivery comprises:

- 1 CAS51D sensor (in the version ordered)
- 1 set of Operating Instructions BA459C/07/en

Accessories

Assemblies

Wastewater assembly Flexdip CYA112

- Modular assembly system for sensors in open basins, channels and tanks
- Versions in stainless steel or PVC
- Ordering acc. to product structure (Technical Information TI432C/07/en)

Flow assembly for CAS51D

- For small flow rates
- Connection: Hose 6 mm OD
- Material: PVC-U
- Two retaining brackets for CAS51D
- Order number: 71110000

Flow assembly Flowfit CYA251 for CAS51D

- Connection: see product structure
- Material: PVC-U
- Ordering acc. to product structure

Holder system

Holder system Flexdip CYH112 for water and wastewater assembly Flexdip CYA112

- Modular holder system for sensors and assemblies in open basins, channels and tanks
- The holder system CYH112 works for nearly any type of fixing - fixing on the floor, wall or directly on a rail.
- Material: stainless steel
- Ordering acc. to product structure (Technical Information TI430C/07/en)

Cleaning system

Cleaning system with pressurized air

- Connection: 6/8 mm or 6.35 mm (1/4")
- Order numbers for sensors with 2 mm gap or 8 mm gap:
 - 6 mm (with 300 mm hose and 8 mm adapter) order number: 71110787
 - 6.35 mm (1/4") order number: 71110788
- Order numbers for sensors with 40 mm gap:
 - 6 mm (with 300 mm hose and 8 mm adapter) order number: 71126757
 - 6.35 mm (1/4") order number: 71126758

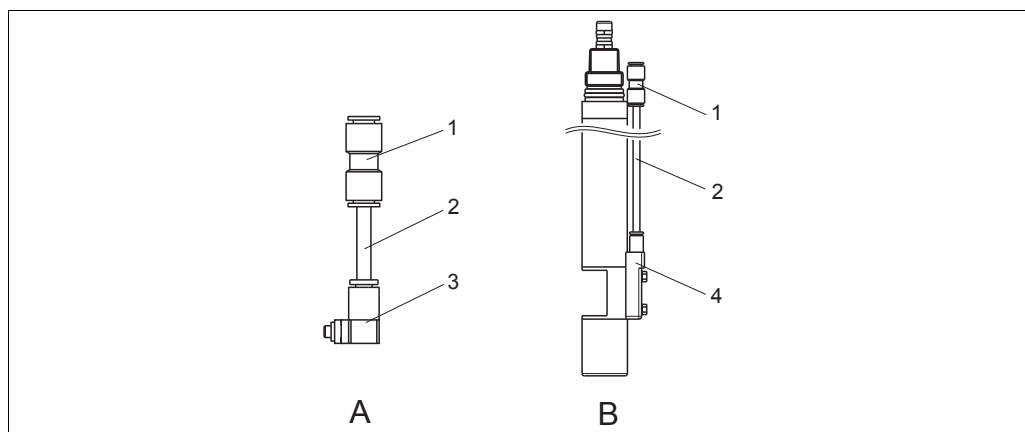

Cleaning system for CAS51D

- A Cleaning system for sensors with 2 mm gap or 8 mm gap
 B Cleaning system for sensors with 40 mm gap
 1 Adapter 8 mm
 2 300 mm hose (Ø = 6 mm)
 3 Hose fitting 6 mm or 6.35 mm (1/4") for sensors with 2 mm gap or 8 mm gap
 4 Hose fitting 6 mm or 6.35 mm (1/4") for sensors with 40 mm gap

Compressor

- For cleaning system
- Including 10 m (32.8 ft) pneumatic hose
- 230 V AC order number: 51504764
- 115 V AC order number: 51504765

Transmitter

Liquiline CM44x

- Multiple-channel transmitter for the connection of digital sensors with Memosens technology
- Power supply: 85 to 265 V AC, 18 to 36 V DC or 20 to 28 V AC (not CM448)
- Universally upgradeable
- SD card slot
- Alarm relay
- IP 66
- Ordering acc. to product structure (Technical Information TI444C/07/en)

Standard buffer solutions

Nitrate standard solutions, 1 liter

- Standard 5 mg/1 NO₃ - N; order no. CAY342-V10C05AAE
- Standard 10 mg/1 NO₃ - N; order no. CAY342-V10C10AAE
- Standard 15 mg/1 NO₃ - N; order no. CAY342-V10C15AAE
- Standard 20 mg/1 NO₃ - N; order no. CAY342-V10C20AAE
- Standard 30 mg/1 NO₃ - N; order no. CAY342-V10C30AAE
- Standard 40 mg/1 NO₃ - N; order no. CAY342-V10C40AAE
- Standard 50 mg/1 NO₃ - N; order no. CAY342-V10C50AAE

| Standard solution | |
|---------------------|------------------------------|
| 1 | Ammonium nitrate, 1 molar |
| Container size | |
| A | 250 ml (8.45 fl.oz.) |
| Transport documents | |
| 1 | Standard documents |
| 2 | Incl. dangerous goods sheets |
| 3 | Safety data sheet |
| Certificate | |
| A | None |
| B | Manufacturer's certificate |
| CAY40- | Complete order code |

Standard solution potassium hydrogen phthalate KHP

- CAY451-V10C01AAE, 1000 ml parent solution 5 000 mg/1 TOC

Instruments International

Endress+Hauser
Instruments International AG
Kaegenstrasse 2
4153 Reinach
Switzerland

Tel.+41 61 715 81 00
Fax+41 61 715 25 00
www.endress.com
info@ii.endress.com

Endress+Hauser 
People for Process Automation